



Client \_\_\_\_\_ Quantity \_\_\_\_\_  
 Project \_\_\_\_\_ Position \_\_\_\_\_

## Levtronic 650 Lt cabinet

**Model:** A80/1BFH

**Cod:** A32080900101

### Technical data

<b>Max capacity:</b>	34 trays EN60x40
<b>Gross capacity:</b>	573 lt
<b>Temperature range:</b>	-20°+40°C
<b>Refrigerant unit:</b>	Plug-In
<b>Cooling gas:</b>	R452A
<b>Defrost:</b>	Electric
<b>Valve:</b>	Supplied standard with solenoid
<b>Dimensions:</b>	810×715×2085
<b>Packing dimensions:</b>	905×830×2250 mm
<b>Gross weight:</b>	165 Kg
<b>Voltage:</b>	220-240 V - 50 Hz
<b>Total rate:</b>	1360 W
<b>Absorbed Current:</b>	6,2 A
<b>Cooling capacity:</b>	646 W*
<b>*:</b>	Evap. -30°C Cond. +55°C

### Features

<b>Functions:</b>	Manual proving, retarder prover, continuous cycle, storage
<b>Standard equipment:</b>	20 slides for EN60x40 trays, lock with key, water drain, LED lighting
<b>Control:</b>	4,3" touch screen display with USB port
<b>Doors:</b>	1 door, self-closing with a 105° stop, right hinged
<b>Door gasket:</b>	Magnetic, triple chamber and easily replaceable
<b>Insulation:</b>	75 mm thickness - CFC/HCFC free
<b>Exterior/interior finishing:</b>	Exterior and interior AISI 304 stainless steel. Back, base and internal technical compartment in galvanized/ colaminated steel.
<b>Inner corners:</b>	Rounded for easy cleaning and ensuring maximum hygiene
<b>Handle:</b>	Stainless steel AISI 304, 2 mm thick
<b>Racks and slides:</b>	Stainless steel AISI 304
<b>Feets:</b>	Stainless steel AISI 304, adjustable h 100-150 mm

**COSMO - wi-fi control**

Cosmo è l'innovativa tecnologia wi-fi che permette di connettere e monitorare costantemente da smartphone il fermalievitazione LEVTRONIC. LEVTRONIC può essere anche un Cosmo hub e consentire la supervisione remota di tutti gli apparecchi Coldline a lui collegati. Dall'app Cosmo potrai controllare in tempo reale le condizioni di funzionamento di ogni macchina e ricevere alert in caso di funzionamento anomalo. Cosmo confronta costantemente le prestazioni dell'apparecchio con quelle ideali e, in caso di differenze significative, suggerisce la manutenzione necessaria. Il software LEVTRONIC può ricevere gli aggiornamenti periodici rilasciati, con le più recenti funzionalità sviluppate.



**Technical draw**

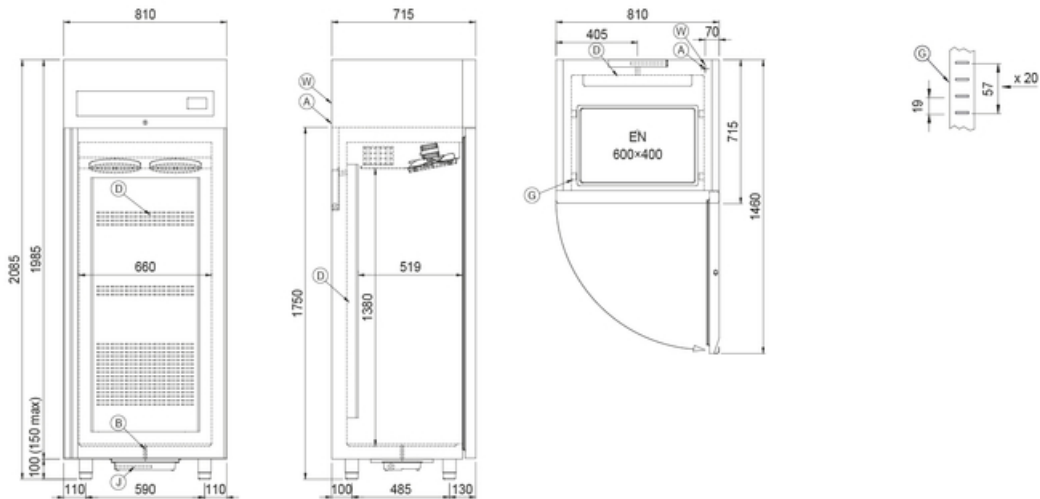

- A:** Power supply cable outlet
- B:** Condensation water drain
- D:** Airflow conveyor
- G:** Racks pitch
- J:** Automatic evaporation of condensing water
- W:** Water mains connection - 3/4 female

In order to constantly offer the best possible products we reserve the right to make changes on technical specifications without incurring any obligation for equipment previously or subsequently sold.